

User Manual

English



Sequencer Control Option **BE3200**

Document version 1.3 - September 2018

References made to the Perception software are for version 7.00 or higher

For HBM's Terms and Conditions visit www.hbm.com/terms

HBM GmbH
Im Tiefen See 45
64293 Darmstadt
Germany
Tel: +49 6151 80 30
Fax: +49 6151 8039100
Email: info@hbm.com
www.hbm.com/highspeed

Copyright © 2018

All rights reserved. No part of the contents of this document may be reproduced or transmitted in any form or by any means without the written permission of the publisher.



Perception Sequencer Control

LICENSE AGREEMENT AND WARRANTY

For information about LICENSE AGREEMENT AND WARRANTY refer to www.hbm.com/terms.

Table of Contents		Page
1	About this manual	7
1.1	Symbols used in this manual	7
1.2	Manual conventions	8
2	Introduction	9
2.1	BE3200 Test Sequencer Option in Perception	9
3	Installation	10
3.1	Requirements	10
3.1.1	System requirements	10
3.2	Software Installation	11
3.2.1	Installation of Sequencer option in Perception	11
3.2.2	Serial communication port	12
4	Getting Started	13
4.1	Initial check	13
4.2	Introduction to Terminology	14
4.2.1	Synchronization modes	15
4.2.2	Additional synchronization parameters	17
4.2.2.1	Clocks per cycle	17
4.2.2.2	Frequency	17
4.3	Introduction to the Sequencer Option	19
4.3.1	Start the software	19
5	Control and Usage	25
5.1	Introduction	25
5.2	Using the Sequencer option	26
5.3	Output channel selection and modification	33
5.3.1	The Parameter entry bar	33
5.3.2	Mouse control	34
5.4	Programming considerations	35
5.4.1	Load a default sequence	35
5.4.2	Sequence and synchronization	35
5.4.2.1	Timed Synchronization indicator	36
5.4.3	Repetitive testing/Fast Repeat	36
5.4.4	Set up output channels	37
5.4.4.1	Program the sequence	39
5.4.4.2	Download the sequence	39
5.4.4.3	Start the sequence	40

5.4.4.4	Setting the sequence start conditions	40
5.4.4.5	Input Qualifier settings	40
5.4.5	Software repeat (Timer for conditional start stop)	41
5.5	Sequencer data sources	44
5.6	Configure Sequencer sheet layout	45
5.6.1	Layout	45
5.6.2	Channel display height	47
5.6.3	User Table	49
5.7	Sequencer Run button vs. Acquisition Start	51
6	Advanced operation of the software	52
6.1	Channel Linking	52
6.2	Zooming	53
A	Software changes from TeamSeq	54
A.1	Where has my...function gone?	54
A.1.1	Status bar	55
B	Sequencer User Key Actions	57
B.1	Introduction	57
B.1.1	Decrease pulse length	58
B.1.2	Increase pulse length	58
B.1.3	Disable Sequencer channel	59
B.1.4	Enable Sequencer channel	59
B.1.5	Lock Sequencer channel	59
B.1.6	Unlock Sequencer channel	59
B.1.7	Move pulse start backward	59
B.1.8	Move pulse start forward	59
B.1.9	Set pulse as active pulse	60
B.1.10	Set pulse length	60
B.1.11	Set pulse start	60

1 About this manual

1.1 Symbols used in this manual

The following symbols are used throughout this manual to indicate warnings and cautions.



WARNING

Indicates a potentially hazardous situation which, if not avoided, could result in death or serious injury.



WARNING

Indicates an electrical shock hazard which, if not avoided, could result in death or serious injury.



CAUTION

Indicates a potentially hazardous situation which, if not avoided, could result in minor or moderate injury; or alerts against unsafe practices; or alerts against actions which could damage the product or result in a loss of data.



CAUTION

The ESD susceptibility symbol indicates that handling or use of an item may result in damage from ESD if proper precautions are not taken.



HINT/TIP

The info icon indicates sections which provide additional information about the product. This information is not essential for correct operation of the instrument, but provides knowledge to make better use of the instrument.

1.2 Manual conventions

When the wording “Click Start ...” is used, this refers to the Windows® Start button. Compared to Windows® XP, Windows® Vista and Windows® 7, the Start Menu has undergone some significant changes. The taskbar icon is no longer labeled "Start" and is now simply the pearl icon (of the window-frame in an orb).

2 Introduction

2.1 **BE3200 Test Sequencer Option in Perception**

The Sequencer option enables you to communicate with and control the BE3200 Sequencer. You can freely edit sequence start and stop times and durations within the Sequencer sheet for ultimate control.

In this manual we will describe the additional tools and options that the Sequencer sheet provides and how to use them.

3 Installation

3.1 Requirements

- Perception software is installed
- one free COM port is available for communication with the BE3200 hardware.

3.1.1 System requirements

- TrueColor (24-bit) video display adapter with 64 MB on-board video memory and hardware DirectX 9 support using a screen size of at least 1280 x 900 pixels, recommended 1600 x 1200.

3.2 Software Installation

3.2.1 Installation of Sequencer option in Perception

The Perception software requires a HASP key. HASP (Hardware Against Software Piracy) is a hardware-based (hardware key) software copy protection system that prevents unauthorized use of software applications.



Figure 3.1: HASP key

Each HASP key contains a unique ID number used for personalization of the application according to the features and options purchased. The key is also used for storing licensing parameters, applications and customer-specific data.

If you have purchased the Sequencer option as a separate item, you will receive a personalized "key file". Use this file to unlock the additional features.

You can find the serial number of your key in **Help About Perception To update the key information:**

- 1 Choose **Help ► Update Key...**
- 2 In the Open dialog locate the Key File (*.pKey) and click **Open**.
- 3 If everything is OK you will see the following message:



Figure 3.2: Software copy protection dialog

- 4 Click **OK**.

After the installation you can go to **Help ► About Perception ► More...** to see all installed options

You will need to restart the program before the changes take effect. The Sequencer option is now available.

3.2.2 Serial communication port

The Sequencer option needs an unused COM port to communicate with the BE3200. The Perception software will automatically scan all free ports for the port to which the BE3200 is connected whenever you connect with the software to the BE3200.

Scanning starts at the port which was last used. When the BE3200 is not switched on and you try to connect to the BE3200, the software will report "No BE3200 sequencer connected!". Switch on the BE3200 and connect again.

4 Getting Started

4.1 Initial check

Make sure the following is available:

- Perception Sequencer Option
- Communication link

Note *At this point you can plug-in and power on your BE3200 Test Sequencer.*

4.2 Introduction to Terminology

Definitions

Within the Sequencer Option a number of concepts are defined which are explained in this section.

Sequence

A sequence is defined as a number of timed actions to be performed within a certain interval. A sequence has a start and a finish and can be regarded as one integral undividable operation.

Duration

The time between the start and finish of the sequence is called the duration. The duration of the sequence can be expressed in time, cycle:degrees or half cycles.

Cycle:degree

The cycle:degree notation is derived from the cycles of a sine wave. The unit is one cycle. One cycle of a sine wave is divided into 360 degrees.

Examples:

1:000 equals one cycle

2:180 equals two and a half cycle

Halfcycles

The halfcycle notation is derived from the cycles of a sine wave. The unit is half a cycle. A halfcycle is divided into 100 parts.

Examples:

2.00 equals two halfcycles and equals one cycle:degrees (1:000)

4.10 equals 4 and 10/100 halfcycles which equals two cycles and 18 degrees (2:018)

Start and length

The moment a channel switches from the OFF state to the ON state is called the start. The time a channel is ON is called the length. The start of a channel is referred to the start of the sequence ($t=0$). There are three ways to specify the length:

- Set the length by entering the required value
- Select the short-cut "to end" - of sequence-
- Select the short-cut "pulse"

The following Figure 4.1 shows the main parameters of an output channel's state:

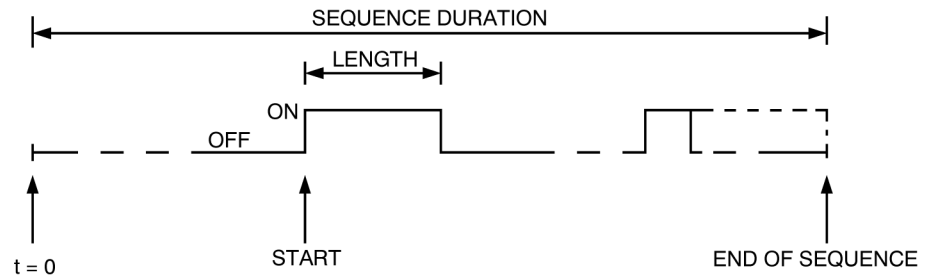

Figure 4.1: Parameters of an output channel's state

Pulse length

For ease of use you can set a pulse length. When the short-cut “pulse” is used to define the length of an ON-state in a channel, automatically this value is used to set the length.

Main delay

The complete sequence (all output channels) can be delayed. This delay can be set anywhere between 0 and 359 degrees of a cycle. Since a sequence is synchronized (starts) with a zero-crossing of the synchronization source, this effectively shifts the complete sequence away from the zero-crossing with the specified amount of main delay.

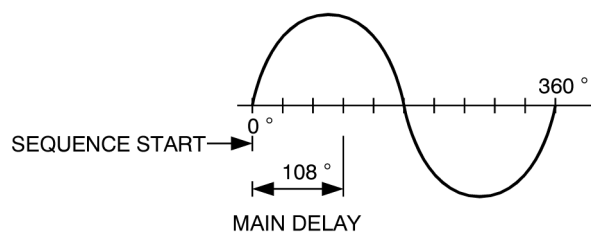

Figure 4.2: Sequence main delay

4.2.1 Synchronization modes

Independent of the selected synchronization source, various synchronization modes are available. These modes are:

- Full
- Timed
- Measured
- None

Full synchronization

When full synchronization is selected, the BE3200 locks its internal timing to the synchronization source and uses the synchronization source during the complete sequence to verify its timing. This is depicted in the following Figure 4.3.

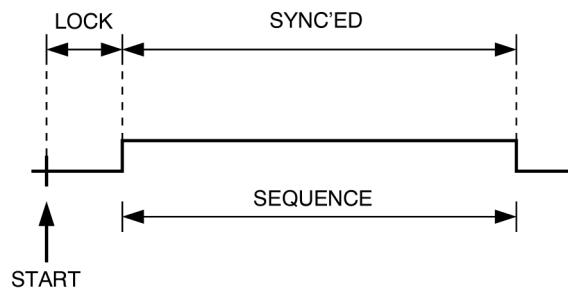

Figure 4.3: Full synchronization

The sequence starts at a zero index pulse.

Timed synchronization

When timed synchronization is selected, the BE3200 locks its internal timing to the synchronization source and verifies its internal timing with the synchronization source only for a specified time interval from the actual start of the sequence as shown in the following Figure 4.4.

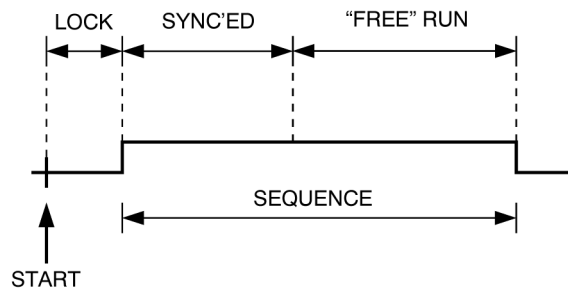

Figure 4.4: Timed synchronization

When the specified time has elapsed, the BE3200 continues to operate with the last measured synchronization values.

The sequence starts at a zero index pulse.

Measured synchronization

When measured synchronization is selected, the BE3200 locks its internal timing to the selected synchronization source. At the start of the sequence the BE3200 continues to operate with the last measured synchronization values. The sequence starts at a zero index pulse.

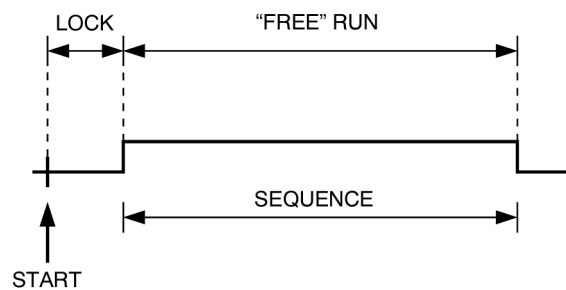

Figure 4.5: Measured synchronization

No synchronization

When “none” is selected as synchronization mode, the BE3200 uses the parameters as set by the software for its internal timing.

The start of the sequence is after receipt of a start command.

4.2.2 Additional synchronization parameters

Clocks per cycle

The number of clock pulses per cycle can be set. This parameter is used to verify the clocks per cycle of the generators 1 and 2 with clock and zero as the synchronization source is selected. When the set number of clocks per cycle does not match the measured clocks per cycle, an error is generated.

Frequency

The frequency can be set. This parameter is used to verify the frequency of the synchronization source. When the set nominal frequency - plus or minus the set maximum deviation does - not match the measured frequency, an error is generated.

Note *This frequency is also used to calculate the correct number of cycle:degrees for the correction factor, main delay and when no sync mode is selected. It is also required for a correct conversion between milliseconds and cycles.*

4.3 Introduction to the Sequencer Option

4.3.1 Start the software

Once you start Perception and the Sequencer option is installed you should be able to see a new tab available in the tabbed sheet bar.

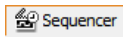

If you select the Sequencer tab the Sequencer sheet should come up as shown in the following Figure 4.6.

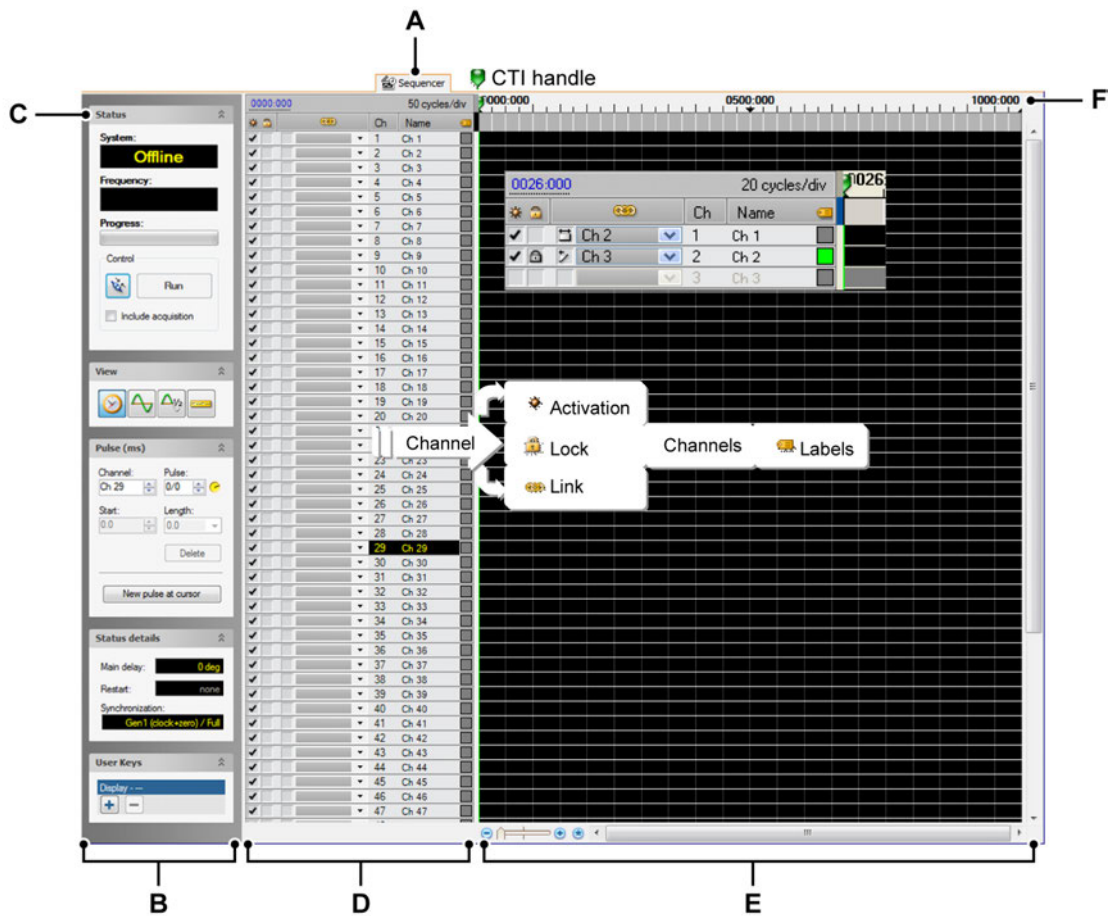

Figure 4.6: Sequencer Sheet

- A Sequencer Tab
- B Task Pane
- C Groups - (Status group)
- D Channel Options Pane
- E Display Area
- F X-Axis Annotation

A Sequencer Tab

Click The Sequencer tab to bring the Sequencer sheet on top.

- **Sequencer Sheet:**

This Sheet contains all the main data and information on the pulses and channels; including state of activation, whether the channel is active or locked, the name of the channel and its corresponding optional label.

- **Channel names:**

Text strings are assigned to a channel, they can be changed at any time and are any length however only a certain amount of characters can be visually displayed under the channel name.

B The **Task pane** contains the following groups:

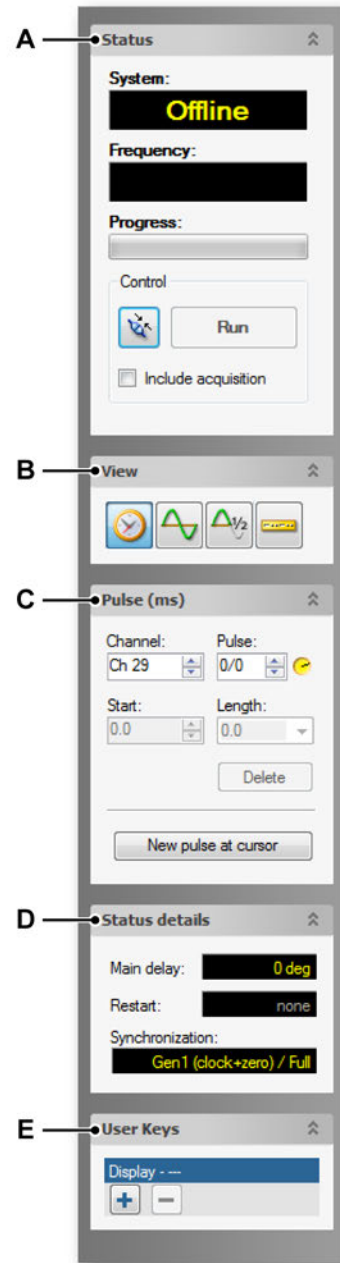

- A Status group
- B View group
- C Pulse group
- D Status details group
- E User Keys group

C Groups

The **Status group** Shows the main Sequence controls and displays

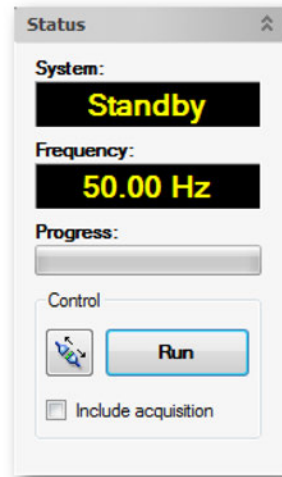

The displays show the **system** status (offline, configuring, standby or running) and the measured **frequency** of the synchronization source. It also shows the **progress** of an operation controlled by this group. The control box allows you to **connect** or disconnect to the BE3200 and to **run** a sequence once connected. There is also a check box to **include** an **acquisition**.

System **Status**:

- **Offline** No connection or communication with hardware available. This can be true when a sequence is created or modified without connected hardware.
- **Standby** Sequencer hardware is online, i.e. there is communication with the hardware. Setting modifications will be sent immediately to the hardware.
- **Running** The hardware is busy executing a sequence.
- **Waiting** When the software has been set up to execute more than one sequence (repeat mode enabled) this status is shown between consecutive tests. In the last 30 seconds between two tests the message is replaced by a down count of one count per second.

The measured **frequency** display shows the actual measured frequency of the selected synchronization source.

View group Provides a way to easily change between the timing units used in Sequencer.



Figure 4.7: View group

Pulse group Shows your interactive channel and pulse information. You can also **delete** and create **new pulses** from this panel.

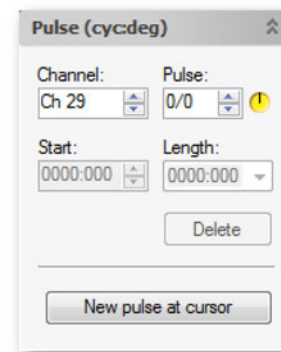

Figure 4.8: Pulse group

- **Channel** name is the text string in the Channel field.
- **Pulse** Shows the current pulse number out of the total number of pulses in a channel.
- **Phase** 🕒 Is the phase of a selected pulse in that channel.
- **Start** time indicates the start time of the selected pulse in the output channel.
- **Length** of pulse indicates how long the selected pulse will remain in the On-state.

Status details group

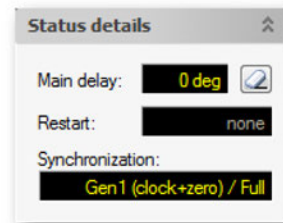

Figure 4.9: Status group

- **Main delay** Shows the main delay in the units selected (for the complete sequence).
- **Restart** Shows the current sequence restart status.
- **Synchronization** Shows the current mode of synchronization.

The **User Keys group** can be used to configure **User Keys**. See Perception User Manual for details on User Keys in general and Sequencer specific User Keys.

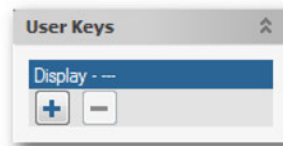

Figure 4.10: User Keys group

5 Control and Usage

5.1 Introduction

For control of the BE3200 the Sequencer Option is provided. You are provided with 128 channels to work with and a variety of options which are described in the following section.

This chapter will guide you through the various steps, required to obtain a general understanding of the concepts used in the Sequencer Option and an introduction to the contents of the Sequencer Option sheet.

5.2 Using the Sequencer option

The following highlights the main areas for control of the Sequencer option.

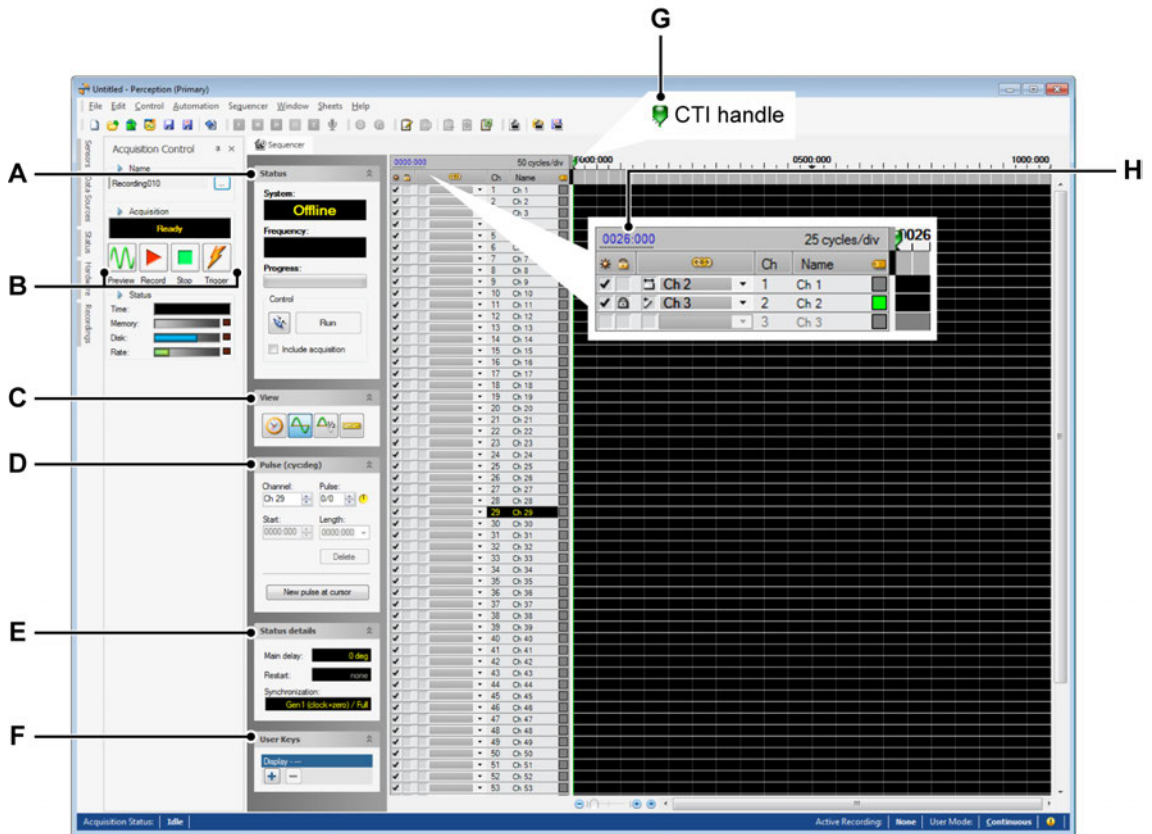



Figure 5.1: Sequencer tab

- A** Status group
- B** Acquisition controls
- C** View group
- D** Pulse group
- E** Status group
- F** User Keys group
- G** CTI (Current time indicator) value
- H** CTI handle

- A Status group** Select the task pane where the connect button is located. At first the **Run** button should be greyed out. Click the connect button  to start the communication link.

When connected you will be able to click the **Run** button.



The following will be displayed in the status pane.

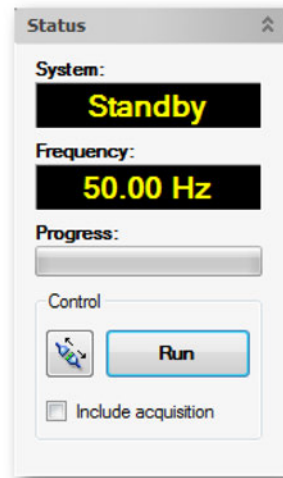

Figure 5.2: Status group

The system status should read **Standby**.

Note *At this point at least the following indicators on the BE3200 front panel must be on:*

- *Power on*
- *Sequencer on line*
- *Communication OK*

The measured **frequency** display shows the actual measured frequency of the selected synchronization source.

B Acquisition controls

Note *Acquisition controls are not part of the Sequencer option please refer to the Perception User Manual for further information.*

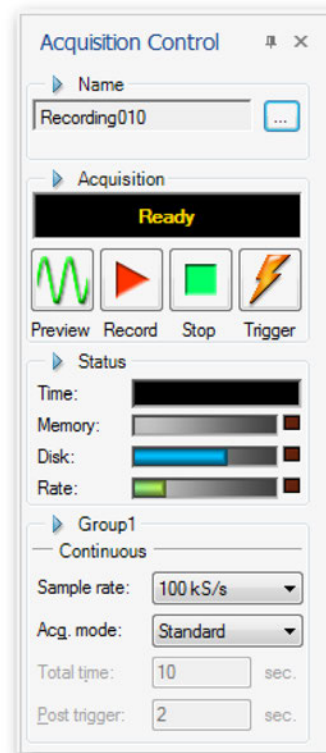





Figure 5.3: Acquisition controls

Figure 5.3 includes controls which can also be used to control a sequence, see additional information in chapter “Sequencer Run button vs. Acquisition Start” on page 51.

- C View group** Click the following buttons to change the units displayed in the Pulse group, the Channel options pane including the CTI value and the ms/div as well as the x-annotation bar.



Figure 5.4: View group

-  **Time**
Click Time to display pulse information in seconds
-  **Cycles** (cycles and degrees)
Click cycles to display pulse information in units of degrees, where one cycle is 360 degrees
-  **Half Cycles** (half cycles and degrees)
Click half cycles to display pulse information in units of degrees, where one cycle is 180 degrees

Click the following button to activate the Pulse Parameter entry bar:

-  **Pulse Parameter Entry Bar** View or hide the Pulse Parameter Entry Bar. For further information see "The Parameter entry bar" on page 33.

D Pulse group

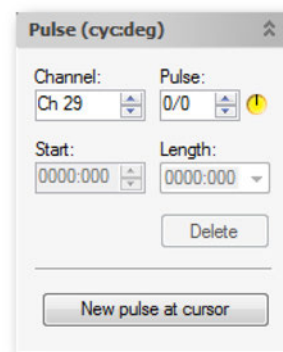

Figure 5.5: Pulse group

From the pulse group you can change the characteristics of a pulse, delete or create a new one. Click **New pulse at cursor** to insert a pulse in the highlighted channel starting from the CTI handle. Click the arrows in **Channel, Pulse** or **Start** to increase or decrease the value in that field. Click the drop down box **Length** to choose the length of a pulse, either a short **Pulse** or a pulse that stretches to the end of the sequence (**To end**). In all boxes you may enter a value manually using the keyboard. Click **Delete** to remove the selected pulse.

E Status details group

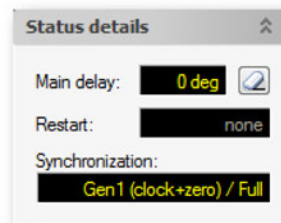

Figure 5.6: Status details group

To change this information point to the menu bar **Sequencer ► Sequence...► Sequence and Synchronization** tab in the dialog box. In the **Status details** group next to the **Main delay** there is a button which will reset the main delay when clicked.

- F User Keys group** group can be used to configure User Keys (see Perception User manual).
 User Keys in general and Sequencer specific (see Perception User Keys and Macros User manual).
 User Keys are described in the appendix “Sequencer User Key Actions” on page 57.

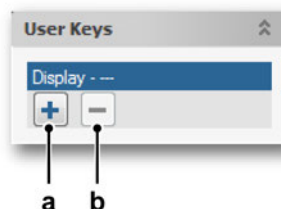



Figure 5.7: User Keys group

- a**  Add new User Key

b  Remove User Key

Clicking the right mouse button on the User Keys group shows following context menu.

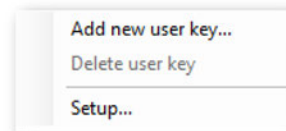

Figure 5.8: User Keys context menu

Figure 5.9 shows the layout of the User Keys group when several User Keys are added.



Figure 5.9: User Keys added

G CTI (Current time indicator) value Displays the position of the cursor:



Figure 5.10: Cursor value (Detail)

Embedded in this control are additional features. Double click this control to enable manual input of the CTI value.

H CTI handle Click and drag this control field to adjust the position of the CTI.

Initially the CTI handle  is located in the top left hand corner of the display. Use the handle to drag the CTI into the display area. The CTI value will be shown in the top left corner of the sheet.

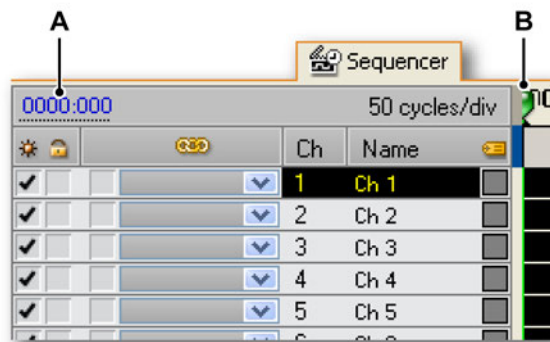

Figure 5.11: Sequencer sheet (Detail)

- A** CTI value
- B** CTI handle

5.3 Output channel selection and modification

At startup the topmost output channel is selected. This active line is shown by means of an inverted text line channel number and name. There are several ways to move around the various channels and modify them:

- Pulse group in the task pane
- Parameter entry bar
- Mouse

For the Pulse group please refer to the section “Using the Sequencer Option” Figure 5.5 on page 29.

5.3.1 The Parameter entry bar

To activate click the Parameter entry bar button  in the view group in the task pane.

Note *The parameter entry bar appears one line below the active line.*

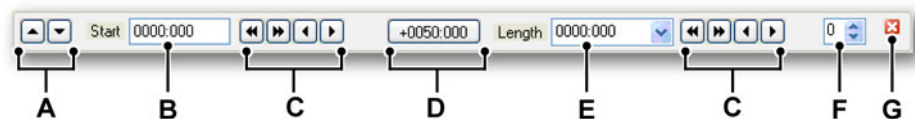

Figure 5.12: Parameter entry bar

- A** The Up/Down keys are used to move the parameter bar between channels.
- B Start:** The readout and manual input of the X-position of a trigger.
- C** Controls to increase or decrease the X-position of triggers

Click to increase or decrease in the smallest available increments:



Click to increase or decrease in larger increments:



- D** Click this button to increase the start position of a trigger by 0050:000.
- E Length:** The readout and manual input of the length/on-state of a trigger.
- F** The Pulse number displays which pulse is selected in a channel.
- G** The Close button to remove the parameter entry bar

5.3.2 Mouse control



Mouse dragging is another way to manipulate the pulse dimensions or on states. Activate a pulse by clicking on it once and it will highlight.



On mouse hover you will see the double arrow symbol.

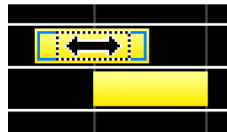

If you now select the pulse along the length of the pulse you will see a selection box appear



To change the length of the pulse you can click on the ends of the pulse to drag it in either direction.

- Beginning of Pulse. See figure (A)

A

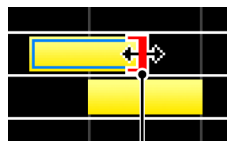

- End of Pulse. See figure (B)

B

When dragging, the start and length values of the selected On-state are continuously updated to reflect the actual position.

At any time when dragging: select the **Esc** key on your keyboard to cancel the operation.

The software allows you to create overlap between two (or more) On-states. This overlap is not visible on the display however. The Sequencer itself accepts this situation and will use the start and end time of the complete area. Therefore it is possible to create more On-states than you can distinguish at first glance on the screen. An easy way to verify is stepping through the various states by means of the left/right arrow keys.

5.4 Programming considerations

Create a sequence

To create a sequence a number of steps have to be taken. This section describes the flow of operations required to set up a sequence.

5.4.1 Load a default sequence

To make a fresh start, select **New Sequence** or **Load Sequence...** from the **Sequencer** menu.

If you have already defined and saved a sequence with settings which you would like to use again, click **Load Sequence...** from the **Sequencer** menu and then immediately after click **Save Sequence as...** from the **Sequencer** menu to save this sequence with a new name. This is to prevent accidental changes in the sequence you have already created. In general: save your work often to prevent loss of data and time.

5.4.2 Sequence and synchronization

In general the first thing you should do is the definition of the sequence parameters. Select **Sequencer** in the menu bar in then select **Sequence...** the **Sequence Setup** window comes up. Here you can define the **Duration** of the Sequence and set the **Main delay**.

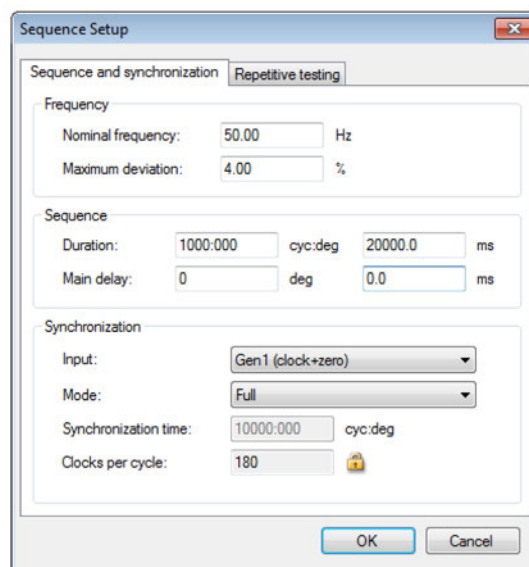

Figure 5.13: Sequence and Synchronization dialog

A **Nominal frequency** must be filled in to reflect the actual situation. These numbers are used for verification of the synchronization source and for conversion between time and cycles. The error in the signal is defined using **Maximum Deviation**.

Sequence parameters can be changed for the duration of a test sequence in cycles and degrees and for the Main Delay in *degrees*, both are shown in *ms*.

Settings for the type of Synchronization can also be changed. The input can be a mains signal or generated. The **Mode** can be switched between **Full**, **Timed** (a set time), **Measured** (continuous) or **None**. Synchronization time is only available in **Timed** mode and **Clocks per cycle** is available in all except **None** mode.

Timed Synchronization indicator

When timed synchronization is selected:

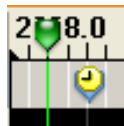

A small yellow clock icon is displayed above the display area. This icon indicates what the active **Synchronization time** is. You can drag this icon along the x-annotation bar to change the **Synchronization time**. A double click on this indicator will call up the **Sequence and synchronization** setup dialog window.

5.4.3 Repetitive testing/Fast Repeat

If you want to add a shift in your main delay between multiple tests you can do that here along with the option to enable fast repeating for endurance testing. You may choose shifts in set steps or randomized shifting which is used for a more accurate statistical representation of results.

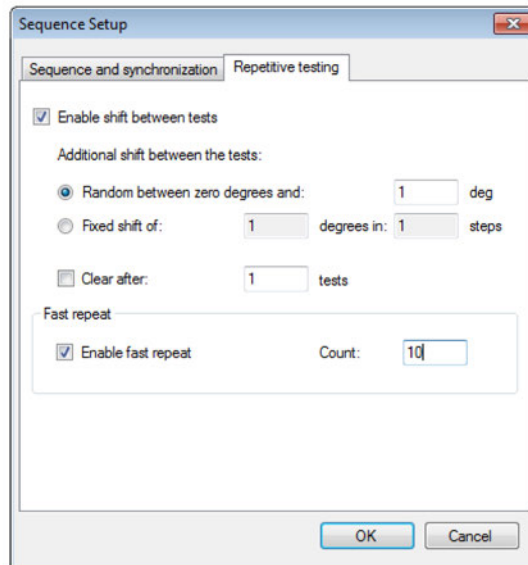

Figure 5.14: Repetitive testing dialog

First click the check box to **Enable the shift between tests** mode.

Although each test uses the same sequence, you can make small modifications to each test by using a **Random** or **Fixed shift** for each sequence.

Firstly select enable shift between tests.

- When **Random** is selected, the main delay will be a random value between and including 0 and the set value (integer degrees).
- When **fixed shift** is selected, the shift delay is incremented each time with degrees/steps degrees. E.g. 180 degrees in 10 steps yields 18 degrees increments per test

5.4.4 Set up output channels

Once the overall sequence parameters have been set up, each specific output channel must be configured. To do this click **Output...** in the **Sequencer** menu or double-click on the name of a specific channel. Now the Output configuration window comes up.

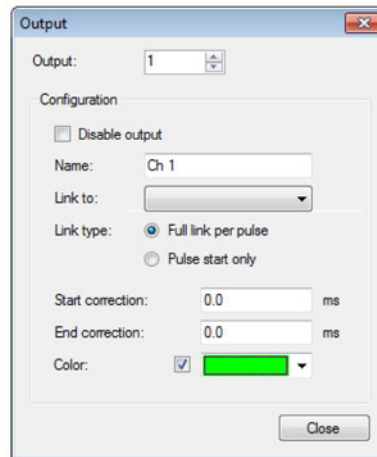

Figure 5.15: Output dialog

The Output configuration window comes up with the currently selected output channel. You can type in another channel name or use the arrows to step through the available channels.

Each channel has a descriptive name. Type this name in the **Name** entry field.

Click **Disable output** to remove the complete selected line from the active sequence.

When you want to link a channel to another channel with the **Full link per pulse** option checked, all program settings (except for output correction) of the second channel are dynamically copied to the first channel. When you program the second channel, the settings are automatically copied to the first channel. E.g. when you link channel 2 to channel 1, channel 2 will use the settings of channel 1.

When you select the **Pulse start only** link option, only the start of each On-state is linked.

Note *You cannot link multiple channels to the same channel. To link multiple channels to each other you must chain link them, e.g. link channel 3 to channel 2 and channel 2 to channel 1. Any program change in channel 1 will now automatically be copied to channel 2 and 3.*

To change the start and end points of the linked pulse you should modify the **Start correction** and **End correction** times. The linked pulse will then adjust its start and end time according to the values in the entry fields.

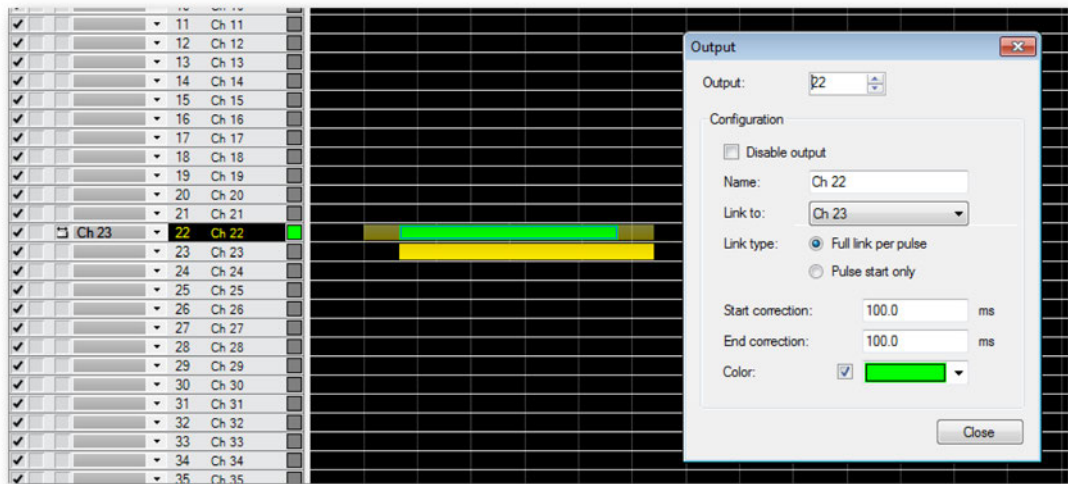

Figure 5.16: Output correction

Note *The maximum Start or End correction is 100ms*

Program the sequence

Once the main sequence parameters have been set up and all output channels to be used are configured you can start to program the Sequencer. For each output channel you can define the start and the length of the active period by using the parameter entry bar as described in "The Parameter entry bar" on page 33.

Download the sequence

There are no special requirements to download the sequence. When the BE3200 is connected to the PC and on-line, all settings are automatically updated in the BE3200.

To make contact with the BE3200 from Sequencer you must select the connect button  in the Status window. When a connection is made the status indicator changes from **Off line** to **Stand by**, the **Run** button will become active and you may run your sequence.

Note *The frequency display in the status window shows the actual measured frequency of the selected synchronization source.*

Start the sequence

To start the sequence, click **Run** in the status window.

Note *When the key-switch on the front of the BE3200 unit is set to Hardware, the run button in the status window will change to a key-button . Meaning the sequence cannot be started by software control.*

Setting the sequence start conditions

In the Menu bar Select **Sequencer ► Conditions...** the dialog **Input Conditions** will appear.

Input Qualifier settings

These are **Input conditions** which must be met before the sequence can be activated. Each row of boxes is called a **Pattern** for which the legend is given below.

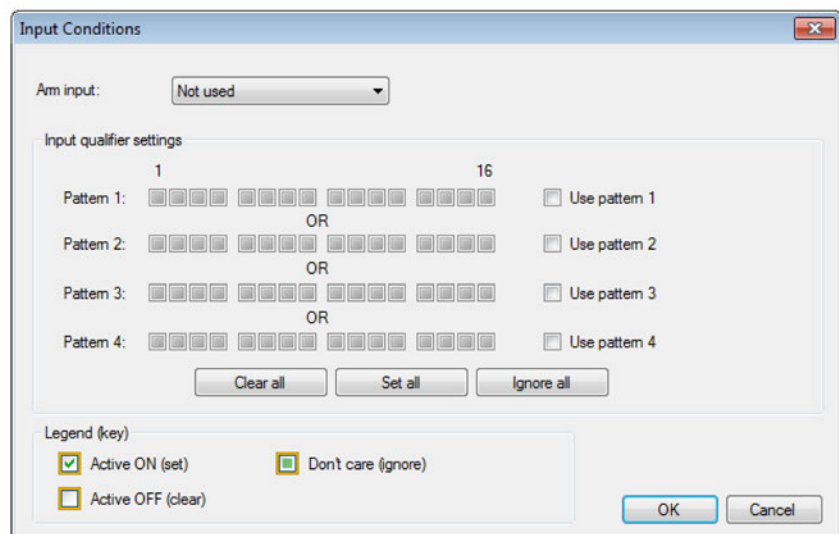

Figure 5.17: Input Conditions

Note *The Legend shows what state is selected for each box. Click repeatedly to cycle through the **Active ON**, **Active Off** and **Don't care** states. **Don't care** simply means you do not have an input state with a meaningful value here.*

There are 4 available patterns that can be pre defined, selected use of each **Pattern** is decided with the check boxes **Use pattern 1,2,3 or 4**, an active **Pattern** has a checked box next to it.

Carefully select the correct pattern for your needs. Running from left to right are the conditions which must be met. For example pattern 1 shows:



Figure 5.18: Input qualifier

The figure 5.10 displays the following logic rule:

IF 1 AND 3 AND NOT 5 AND NOT 7 AND 10 AND NOT 16 are true THEN send signal "OK to start"

To select or deselect all boxes at once click either **Clear all** (Off), **Set all** (On), or **Ignore all** (Don't care).

As an additional safety measure there is also an **Arm input** condition which when selected has to be met inclusively with the **Input qualifier settings**. Select between **High enables start** (a high signal) or **Low enables start** (a low signal) or **Not used** to ignore.

As long as the arm condition is met, a start command may be issued and will be accepted. When the arm condition is false, all start commands, hardware and software, will generate an error message.

5.4.5 Software repeat (Timer for conditional start stop)

The repeat mode **Timer for conditional start stop** (in the **Control** menu) precedes **repetitive testing** in Sequencer and is computer controlled, i.e. each start of the sequence is initiated by computer command. It is generally used for Automation processes over a longer period of time.

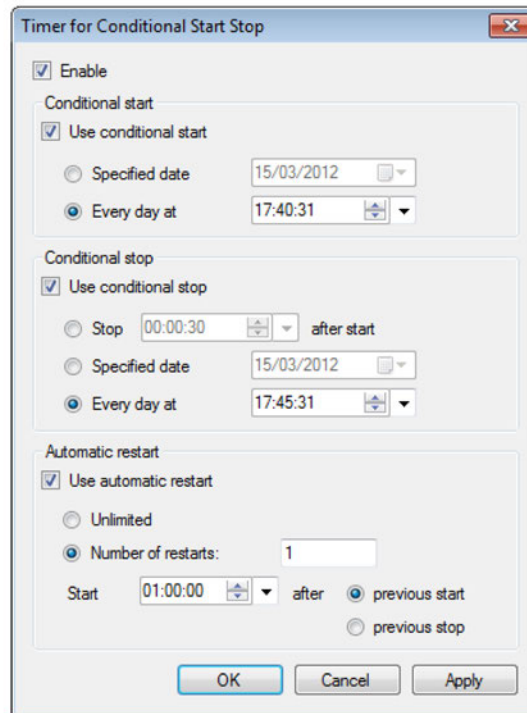

Figure 5.19: Timer for conditional start stop

Click the check box to **Enable** this section and then activate each separate condition with the corresponding check box. The **Use Automatic restart** option will run a number of test restarts at a chosen **Start** time after the **previous start** or **previous stop** time.

In addition to this computer controlled repeat the **Fast Repeat** is available. Refer to "Repetitive testing/Fast Repeat" on page 36 for further details. When this selection is checked the sequence will be repeated the selected number of times without computer control. This repeat count resides within the test Sequencer and once enabled becomes an integral part of the sequence.

The start of the next sequence is almost equal to the end of the previous sequence. There is a small delay between the two consecutive sequences. See also the specifications. The two repeat modes can be combined as shown in the following diagram:

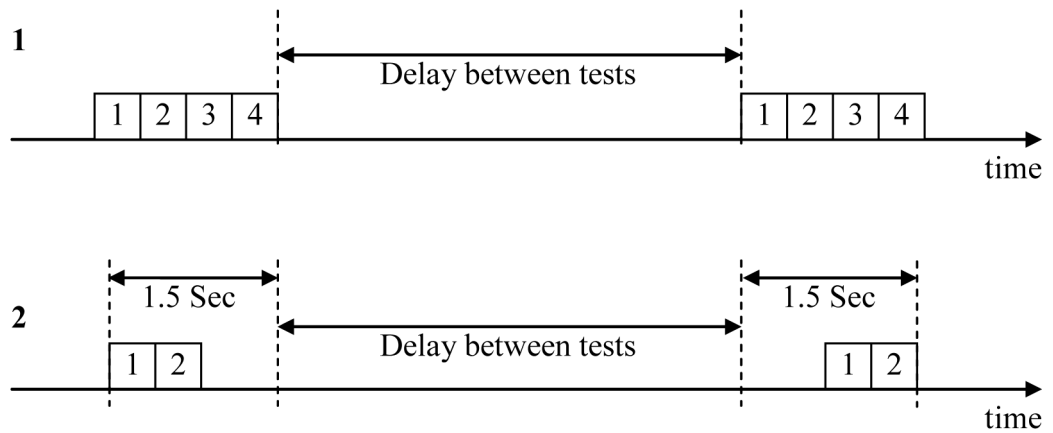

Figure 5.20: Repeat mode diagram

Diagram 1 shows the following situation:

- Sequence duration 1,2,3,4 = 0.5 seconds
- Fast repeat count = 4
- Delay between tests = 4 seconds

Diagram 2 shows the following situation:

- Sequence duration = 0.5 seconds
- Fast repeat count = 2
- Delay between tests = 4 seconds

As shown in Figure 5.20 the minimum duration of a test is 1.5 seconds.

5.5 Sequencer data sources

For configured pulses information of a pulse is available as data sources. See Perception User Manual for details on data sources. The information is listed under category Sequencer in the Data Source Navigator. Following information for each configured pulse is available.

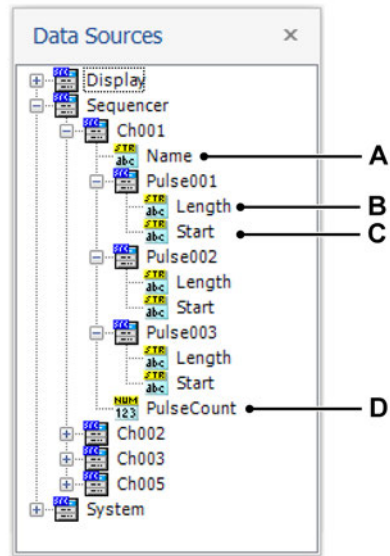

Figure 5.21: Sequencer data sources in the Data Sources Navigator

- A Name** of the channel to which the pulse belongs
- B Length** of each pulse
- C Start** of each pulse
- D PulseCount** Number of configured pulses for each channel

5.6 Configure Sequencer sheet layout

In the Sequencer main menu several menu items can be found which can be used to configure the Sequencer sheet layout.

5.6.1 Layout

When menu item **Layout** is selected the dialogue in Figure 5.23 is shown.

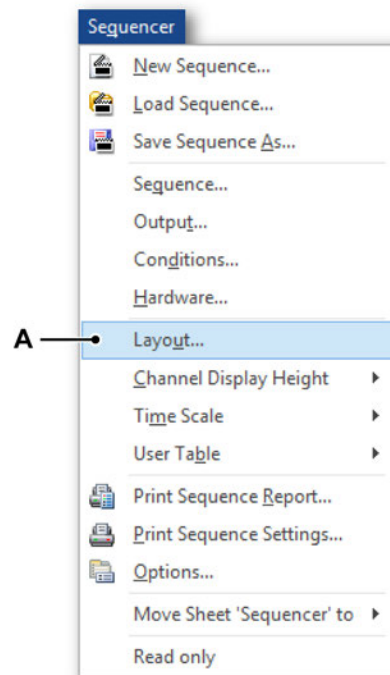

Figure 5.22: Main menu item Layout

A Layout option

In Figure 5.23 the width of the channel name fields and the font size of the channel names can be set. Also the channels which should be shown on the Sequencer sheet can be selected. Channels can be moved to different positions with the blue arrows and can be deactivated by deselecting the check boxes. By default only the first 64 output channels are active.

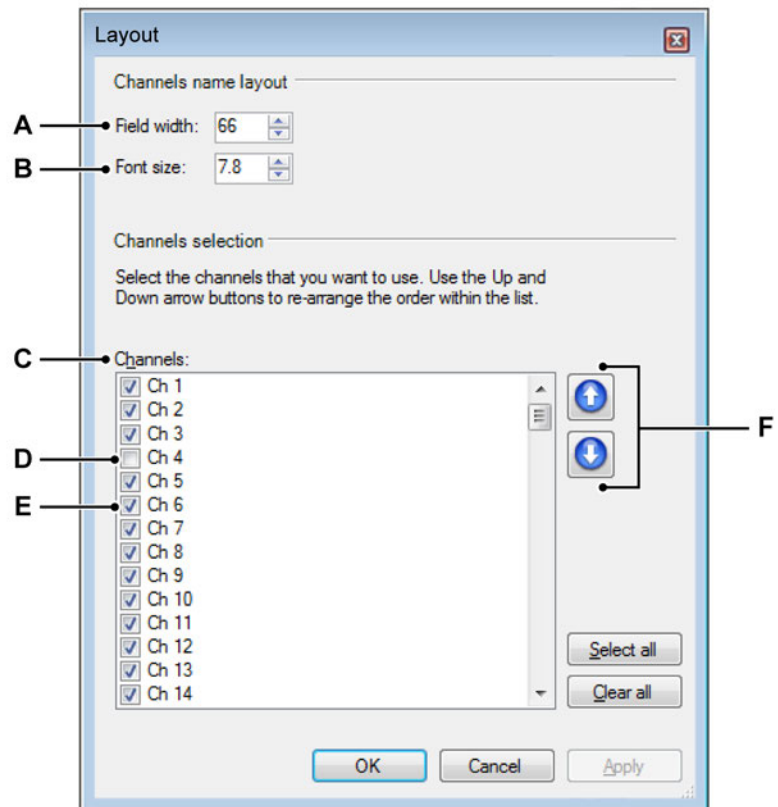

Figure 5.23: Layout dialog

- A Field width** To set the width of a channel.
- B Font size** To set the font size of a channel.
- C Channels** Select which channels should be shown.
- D Check box** To remove a channel from the display clear it's corresponding check box.
- E Check box** To add a channel to the display select it's corresponding check box.
- F Up and down arrows** To move a channel up or down, click the blue up or down arrows.

5.6.2 Channel display height

Menu item **Channel Display Height** can be used to set the height of a channel in the display area. Following heights are possible:

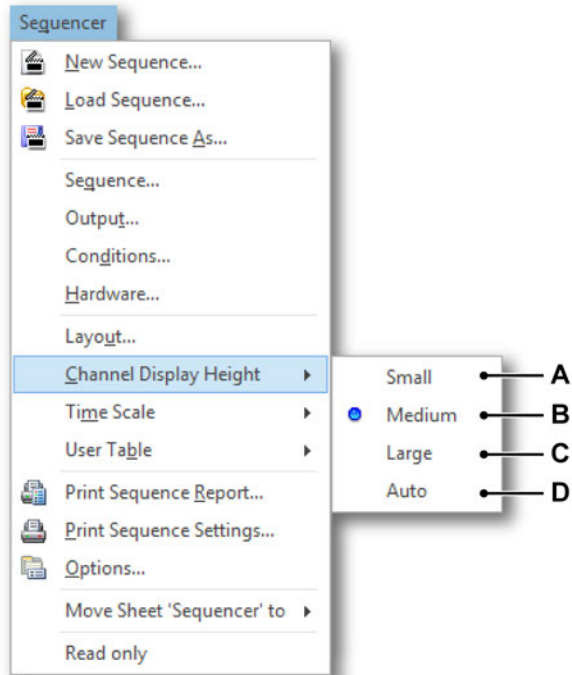

Figure 5.24: Main menu item Channel Display Height

- A Small** Default selection
- B Medium** $2 * \text{Small}$
- C Large** $4 * \text{Small}$
- D Auto** The height of the channels are adjusted to fill the available space in the display area (Small height < Auto height < Large height)

Examples of Channel Display Height settings:

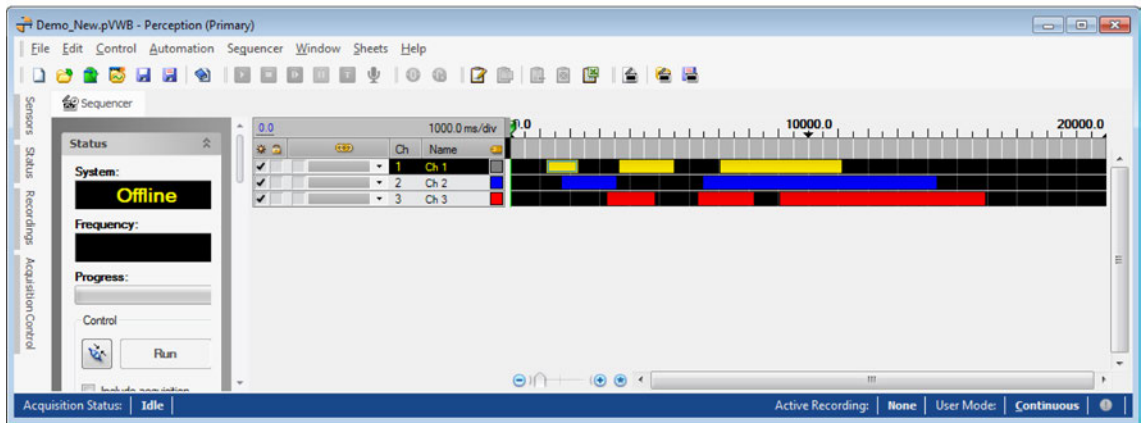

Figure 5.25: Channel Display Height set to Small

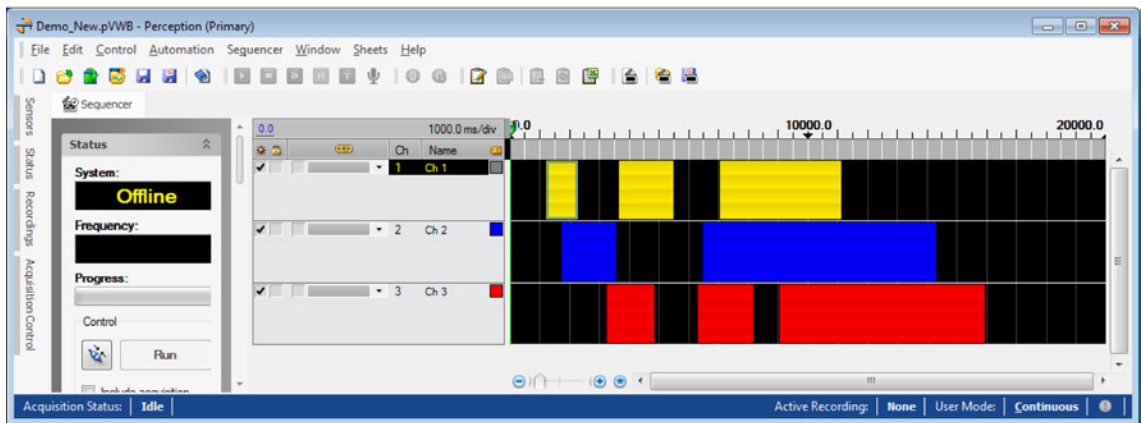

Figure 5.26: Channel Display Height set to Large

5.6.3 User Table

Menu item **User Table** can be used to add a User Table to the Sequencer sheet. See Perception User Manual for details on User Tables. Following options are possible:

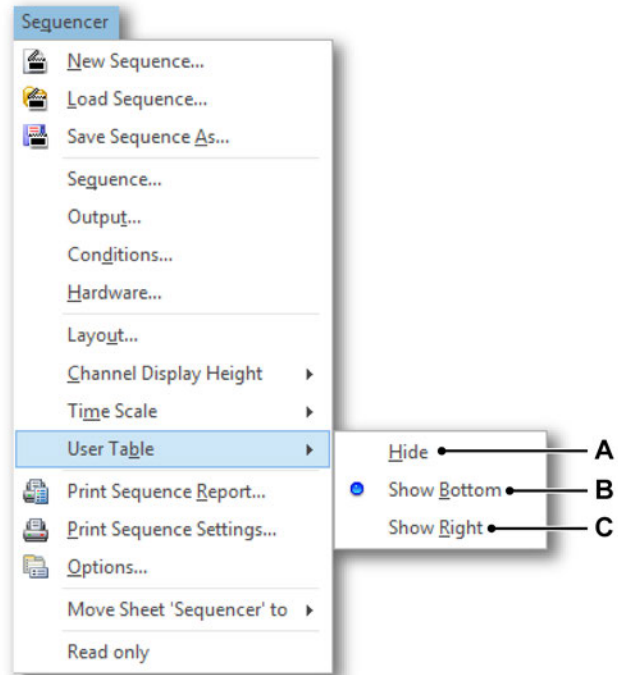

Figure 5.27: Main menu item User Table

- A Hide** No User Table is shown
- B Show Bottom** User Table is added at the bottom of the Sequencer sheet
- C Show Right** User Table is added at the right side of the Sequencer sheet

When a User Table is added the display area is split into two areas. One area contains the channels and the other area contains the User Table. The area size can be adjusted by moving the splitter which separates both areas (see Figure 5.28).

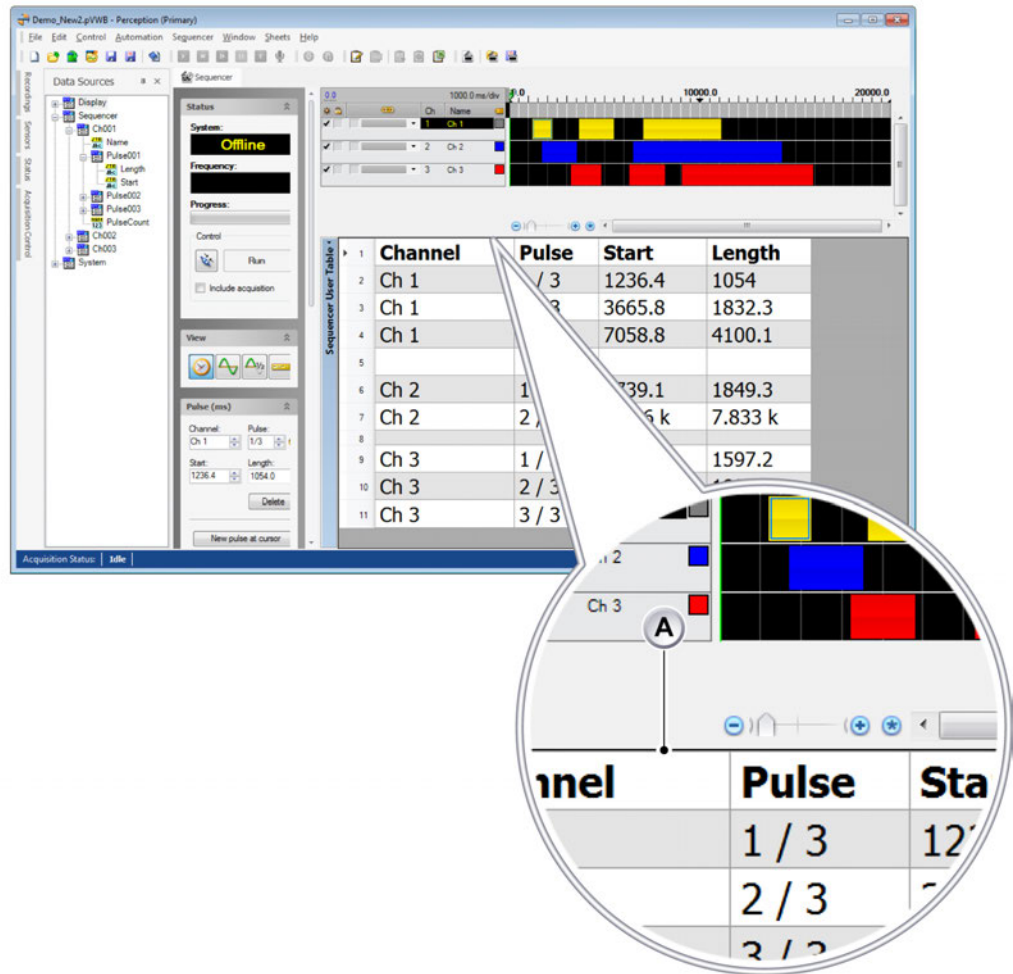

Figure 5.28: User Table showing data source information of configured pulses

A Splitter Move the splitter to adjust the channel and User Table area size

5.7 Sequencer Run button vs. Acquisition Start

Introduction

This section describes the implementation of the start/stop interaction between the Sequencer sheet and the Perception acquisition control.

The Sequencer:

1. After start-up the Sequencer is in *Offline* mode.
2. Click the **Connect** button to set the system on-line and download the currently loaded sequence.
3. Click **Run** to start the sequence.
4. The **Run** command is also sent to the acquisition control. However, this only reaches the acquisition control when the check box **include acquisition** (*synchronize*) is set. If not set, the acquisition is not started and the sequence runs stand-alone

The acquisition control:

5. Click **Start** to start the acquisition.
6. The **Start** button also sends a signal to the Sequencer control. However, this only reaches the Sequencer control when the Sequencer hardware is *on-line*. If not, the sequence is not started and the acquisition runs stand-alone.

6 Advanced operation of the software

6.1 Channel Linking

By selecting the drop down boxes under the  icon you can choose which channels pulses link together.

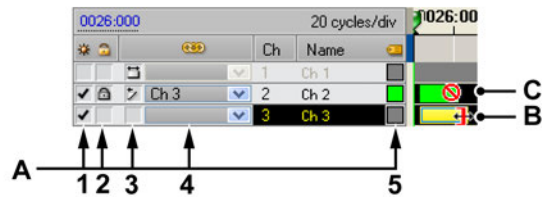

Figure 6.1: Channel area (Detail)

A Clickable areas

- 1 Activation of a Channel, on or off
- 2 Lock Channel to changes
- 3 Link setting, full pulse length or start pulse position
- 4 Channel to link to, so that pulses move together
- 5 Label color

B Extendable pulse cursor Partial linking is possible

C Locked Channel cursor No editing is possible

In Figure 6.1 Channel 1 is linked to Channel 2 from End-to-End of each pulse and Channel 2 is linked to Channel 3 only from the start of the pulse, the clickable icons in 3 show the type of linking used.



This icon shows partial linking is enabled (linked from the start of a pulse).



This icon shows full End-to-End linking is enabled.

6.2 Zooming

For an accurate view of switching events you can zoom in on the time scale. Zooming can be done into the finest detail. Once zoomed, clicking on the star icon at the bottom of the page will bring you back to full view again.

To zoom drag the cursor: click the left mouse button and while keeping it pressed drag the mouse cursor to the required position. Release the mouse button. While dragging, the selected area will be shown on the display as a greyed out part of the graph area.

A Software changes from TeamSeq

A.1 Where has my...function gone?

In this section we will outline the major changes from the Legacy version of the software. You may be used to previous software commands and terminology, this chapter show the most recent commands and terminology changes and where they are currently located.

Legacy File menu	Dynamic menu (Sequencer)
New...	New Sequence...
Open...	Load Sequence...
Save	Save Sequence
Save As...	Save Sequence As...
Print Report...	Print Report...
Print Settings...	Print Settings..
Exit	N/A
<i>Recently Used File List</i>	N/A

Legacy Edit menu	
Copy	N/A
Paste	N/A
Preferences...	Options...

Legacy View menu	Dynamic menu
Time	Time Scale ► Seconds
Cycles	Time Scale ► Cycles
Halfcycles	Time Scale ► Halfcycles
Page ►	N/A (removed page concept)
Page Setup...	Layout...

Legacy Setup menu	Dynamic menu
Synchronization...	Sequence...
Conditions...	Conditions...
Output...	Output...
Sequence...	Sequence...
Repeat...	Sequence...
Step Size...	Options...
Hardware...	Hardware...
Test...	Hardware...

Control menu	
Online	N/A
Start Sequence	N/A
Enable Channel	N/A (moved to annotation area)

Additional Changes	
Endurance testing	Repetitive testing
Main Delay	Shift
Speed bar	Removed
Start button	Run button
Synchronization Input	Gen 1 , Gen 2 (clock and zero / zero), mains
Synchronization sources	No internal - 2 different types for generators

A.1.1 Status bar



Figure A.1: Status bar in Legacy

Status bar	
<p>A Shows the date and time by default. When the cursor is in the graph area it displays the position of the cursor. When a sequence is running it is used to show the progress of the sequence in the form of a bar graph</p>	<p>The date and time have now been removed/hidden.</p>
<p>B Displays the main delay. A right mouse click in this tray will call up the Sequence Setup dialog window.</p>	<p>This has been moved, it is now the first object in the status group.</p>
<p>C Reflects the Repeat count. When a sequence is running it will show the count number and the total repeat number. A right mouse click in this tray will call up the Repetitive Test dialog window.</p>	<p>This has been moved into the menu bar and can be set by navigating to: Sequencer ▶ Sequence ▶ click Repeat testing.</p>

Status bar	
D Shows the synchronization mode. When a sequence is running it will display a warning when the synchronization is lost. A right mouse click in this tray will call up the Synchronization Setup dialog window.	This has been moved to the status group.

B Sequencer User Key Actions

B.1 Introduction

The Sequencer sheet comes with predefined **User Key Actions**. The Sequencer User Keys actions can make it easier to manipulate the position and size of a Sequencer pulse.

Note *For more information about User Keys (general), please refer to the A05025_01_E00_00_Perception User Keys and Macros User manual.*

In this chapter the various **Sequencer** User Keys are described.

Sequencer User Key actions

- 1 [Decrease pulse length](#)
- 2 [Increase pulse length](#)
- 3 [Disable Sequencer channel](#)
- 4 [Enable Sequencer channel](#)
- 5 [Lock Sequencer channel](#)
- 6 [Unlock Sequencer channel](#)
- 7 [Move pulse start backward](#)
- 8 [Move pulse start forward](#)
- 9 [Set pulse as active pulse](#)
- 10 [Set pulse length](#)
- 11 [Set pulse start](#)

B.1.1 Decrease pulse length

 Decrease the length of a Sequencer pulse in the **Set Decrease pulse length** dialog.

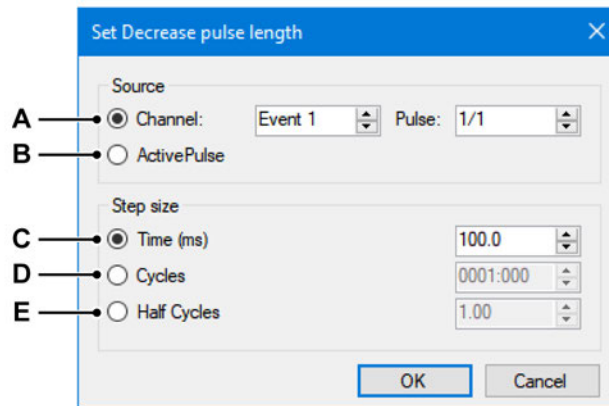



Figure B.1: Set Decrease pulse length

In this dialog you can define if the pulse to be modified should be a predefined pulse of a **Channel (A)** or if the pulse should be the **Active Pulse (B)** in the Sequencer sheet.

The step size to decrease the pulse length can be defined in **Time (A)**, **Cycles (B)** or **Half Cycles (C)**.

B.1.2 Increase pulse length

 Increase the length of a Sequencer pulse.
For more information, please see [Decrease pulse length](#).

B.1.3 Disable Sequencer channel

OFF Disable a Sequencer channel in the **Configure 'Disable sequencer channel'** dialog.

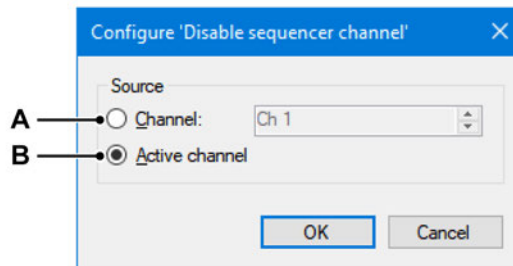



Figure B.2: Disable Sequencer channel

The **Channel (A)** to be disabled can be a specific pre-defined channel or the **Active Channel (B)**.

B.1.4 Enable Sequencer channel

ON For more information, please see [Disable Sequencer channel](#).

B.1.5 Lock Sequencer channel

 Lock a Sequencer channel.
The configuration is similar to [Disable Sequencer channel](#).

B.1.6 Unlock Sequencer channel

 Unlock a Sequencer channel.
The configuration is similar to [Disable Sequencer channel](#).

B.1.7 Move pulse start backward

 Move the start of a Sequencer pulse backwards.
For more information, please see [Decrease pulse length](#).

B.1.8 Move pulse start forward

 Move the start of a Sequencer pulse forwards.
For more information, please see [Decrease pulse length](#).

B.1.9 Set pulse as active pulse

 Set a pulse as the active **Pulse (A)** in the Sequencer sheet in the **Set active pulse** dialog.

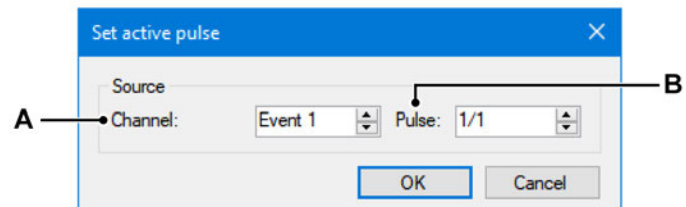



Figure B.3: Set active pulse

Use the configuration dialog to select the **Channel (A)** and **Pulse (B)** to be set active.

B.1.10 Set pulse length

 Set the length of a pulse.
For more information, please see [Decrease pulse length](#).

B.1.11 Set pulse start

 Sets the start position of a pulse.
For more information, please see [Decrease pulse length](#).

Index

A		E	
Active line	33	Enable Channel	55
		Exit	54
C		F	
Cautions	7	File menu	54
Channel		Frequency	17
Link	52	Full synchronization	16
Selection and modification	33		
Clocks per cycle	17	H	
Configure Sequencer sheet layout	45	Halfcycle	
Channel display height	47	Definition	14
Layout	45		
User Table	49	I	
Connect		Installation	
Button	39	Software	11
Control menu	55	Introduction	
Control of the BE3200	25	Sequencer Option	19
Conventions	8		
Conversion		L	
Milliseconds and cycles	18	Length	
Create a sequence	35	Definitions	14
Cycle:degree		of a pulse	15
Definition	18	LICENSE AGREEMENT AND WARRANTY	3
		Link output channels	38
D		Locking	16
Definitions			
Cycle:degree	14	M	
Duration	14	Main delay	
Halfcycles	14	Definitions	15
Main delay	15	Measured synchronization	17
Pulse length	15	Modes	
Sequence	14	Synchronization	15
Start and length	14	Mouse control	34
Delay			
Between tests	43		
Main	15		
Duration			
Definition	14		

N		Setup	
Nominal frequency	17, 36	Sequence	35
P		Setup menu	54
Page		Software	
Setup	54	Installation	11
Parameter entry bar	33	Software repeat	41
Print report	54	Speed bar	55
Print settings	54	Start	
Programming considerations	35	Button	55
Pulse length		Start and length	
Definitions	15	Definitions	14
R		Status	
Repeat		Bar	55
Software	41	Step Size	54
Repetitive testing/Fast Repeat	36	Synchronization	15
Report		Full	16
Print	54	Lock	16
Requirements		Measured	17
System	10	Modes	15
S		Timed	16
Save	54	System	
Save Sequence	54	Requirements	10
Sequence		T	
Create	35	Timed synchronization	16
Definition	14	Timed Synchronization indicator	36
Download	39	U	
Load	35	Usage of the BE3200	25
Repeat	54	Using the Sequencer option	26
Sequence Setup	35	V	
Sequencer data sources	44	View	
Sequencer Option in Perception	9	Zooming	53
Sequencer Run button vs. Acquisition Start	51	View group	29
Sequencer User Key actions	57	N	
Serial		Nominal frequency	17, 36
Port on host	12	P	
Setting		Page	
Start Conditions	40	Setup	54
Settings		Parameter entry bar	33
Print	54	Print report	54
		Print settings	54
		Programming considerations	35
		Pulse length	
		Definitions	15
		R	
		Repeat	
		Software	41
		Repetitive testing/Fast Repeat	36
		Report	
		Print	54
		Requirements	
		System	10
		S	
		Save	54
		Save Sequence	54
		Sequence	
		Create	35
		Definition	14
		Download	39
		Load	35
		Repeat	54
		Sequence Setup	35
		Sequencer data sources	44
		Sequencer Option in Perception	9
		Sequencer Run button vs. Acquisition Start	51
		Sequencer User Key actions	57
		Serial	
		Port on host	12
		Setting	
		Start Conditions	40
		Settings	
		Print	54

Head Office

HBM

Im Tiefen See 45
64293 Darmstadt
Germany
Tel: +49 6151 8030
Email: info@hbm.com

France

HBM France SAS

46 rue du Champoreux
BP76
91542 Mennecy Cedex
Tél: +33 (0)1 69 90 63 70
Fax: +33 (0) 1 69 90 63 80
Email: info@fr.hbm.com

UK

HBM United Kingdom

1 Churchill Court, 58 Station Road
North Harrow, Middlesex, HA2 7SA
Tel: +44 (0) 208 515 6100
Email: info@uk.hbm.com

USA

HBM, Inc.

19 Bartlett Street
Marlborough, MA 01752, USA
Tel : +1 (800) 578-4260
Email: info@usa.hbm.com

PR China

HBM Sales Office

Room 2912, Jing Guang Centre
Beijing, China 100020
Tel: +86 10 6597 4006
Email: hbmchina@hbm.com.cn

© Hottinger Baldwin Messtechnik GmbH. All rights reserved.
All details describe our products in general form only.
They are not to be understood as express warranty and do
not constitute any liability whatsoever.

measure and predict with confidence

